

INSTALLATION AND MAINTENANCE MAMUAL

FOR

Geothermal ground source heat pump

The piping connection should be installed according to the local legal laws and regulations as well as the profession standard.

一、 Pre-installation

1、 Movement and storage

The unit must be moved upside and store at dry area.

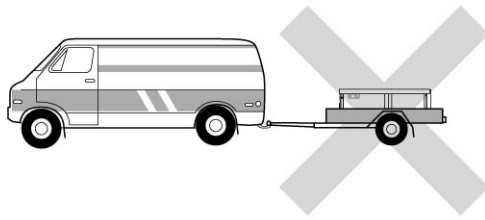
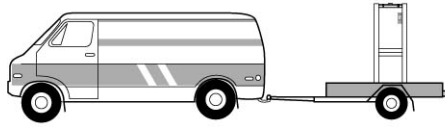

2、 Choice of installation place

The unit must be installed on the strong ground, especially on the concrete surface.

In order to avoid the noise made by the unit. It should be far away from living rooms and others which could not bear noise.

Keep suitable distance between the unit and the building to ensure the normal running and enough maintenance space.

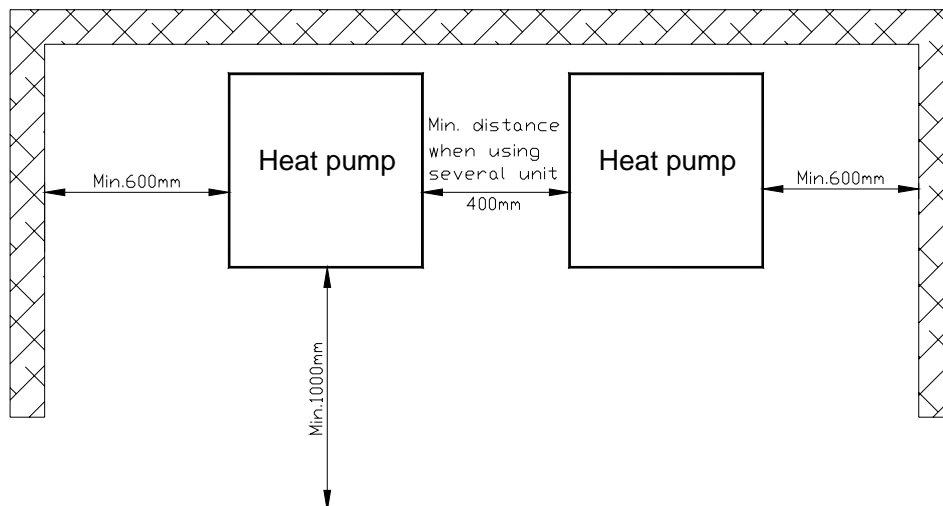

Pipe connections

1、 Floor heating only

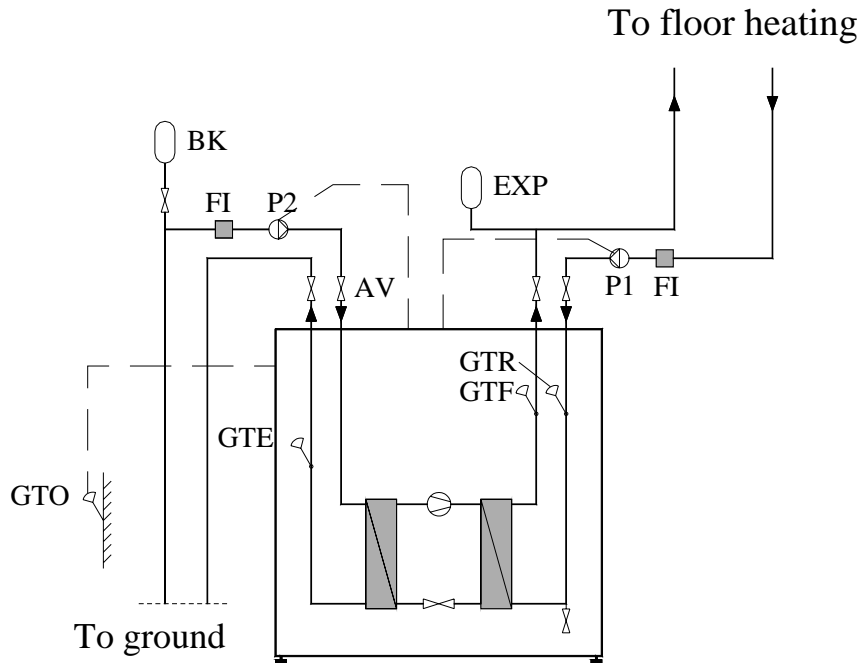

Diagram I

Name	Description	Remark	Name	Description	Remark
P1	Circulation pump	Internal(Optional)	GTR	Return temperature sensor	Internal
P2	Brine pump	External(Optional)	GTF	Flow temperature sensor	Internal
EXP	Expansion tank	-	GTE	Brine water flow sensor	Internal
BK	Brine tank/expansion tank	-	GTO	Outdoor temperature sensor	Internal
FI	Filter	-			
AV	Shut-off valve	-			

Principle of operation (Diagram I)

The unit with floor heating only (exclude daily hot water) installation diagram.

The outdoor temperature sensor (GTV) is a standard part to be installed into the electric box, one terminal is connected with the PC board, the other terminal must be installed outdoor. It should be mounted on the place which can accurately induct the outdoor temperature and not to be exposed under the rain and snow.

The three way valve (VXV) and brine water pump (P2) are controlled by the PC board of the unit.

Pipe connections

2、 Floor heating with hot water

(external water pump and three way revert valve)

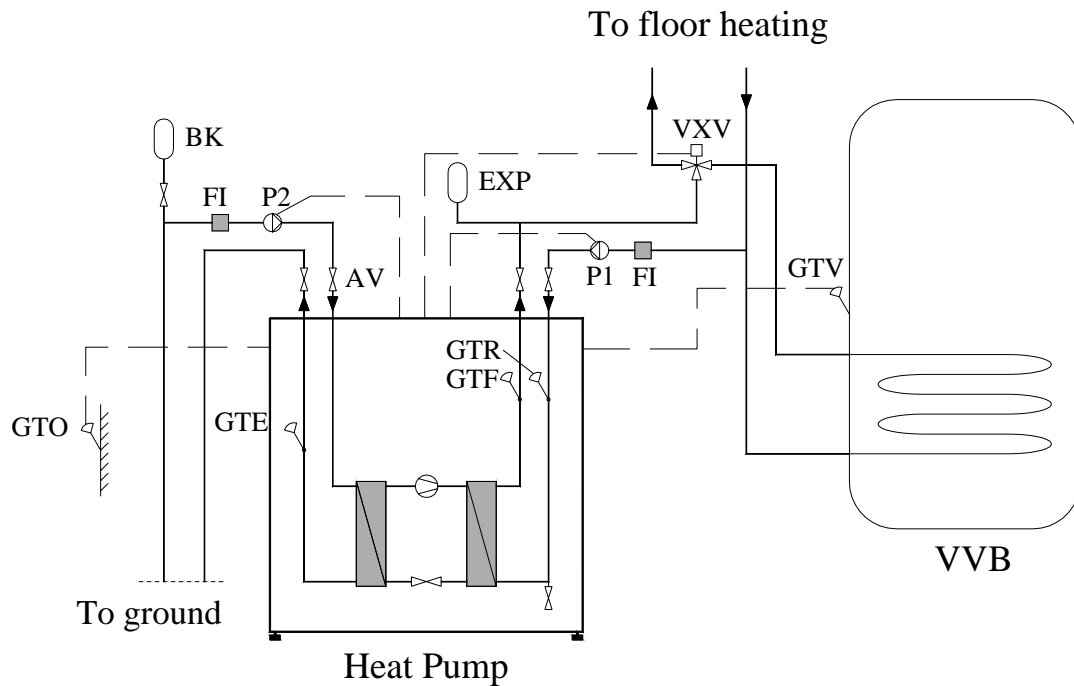

Diagram II

Name	Description	Remark	Name	Description	Remark
P1	Circulation pump	Internal(Optional)	GTR	Return temperature sensor	Internal
P2	Brine pump	External(Optional)	GTF	Flow temperature sensor	Internal
VXV	Change over Valve	Internal(Optional)	GTE	Brine water flow sensor	Internal
VVB	Hot water tank	-	GTV	Hot water sensor	Internal
EXP	Expansion tank	-	GTO	Outdoor temperature sensor	Internal
BK	Brine tank/expansion tank	-			
FI	Filter	-			
AV	Shut-off valve	-			

Principle of operation (Diagram II)

In order to obtain the hot water function, a three way revert valve (VXV) shown on the diagram II must be mounted when install the heat pump system. When daily hot water are required, the three way revert valve (VXV) will have the priority to revert to the hot water tank (VVB). After the daily hot water reach its set temperature, the three way revert valve (VXV) return to its normal floor heating circulation.

In order to have daily hot water function, be sure to switch " X2 " on the PC board to " ON " state (refer to the controller parts).

The hot water temperature sensor (GTV) is a standard part to be installed into the electric box, one terminal is connected with the PC board, the other terminal must be connected with the hot water tank. It should be mounted on the place where can accurately induct the hot water temperature.

The outdoor temperature sensor (GTV) is a standard part to be installed into the electric box, one terminal is connected with the PC board, the other terminal must be installed outdoor. It should be mounted on the place where can accurately induct the outdoor temperature and not to be exposed under the rain and snow.

The three way revert valve (VXV) and brine water pump are controlled by the PC board of the unit.

Pipe connections

3、 Floor heating with hot water

(internal water pump and three way revert valve)

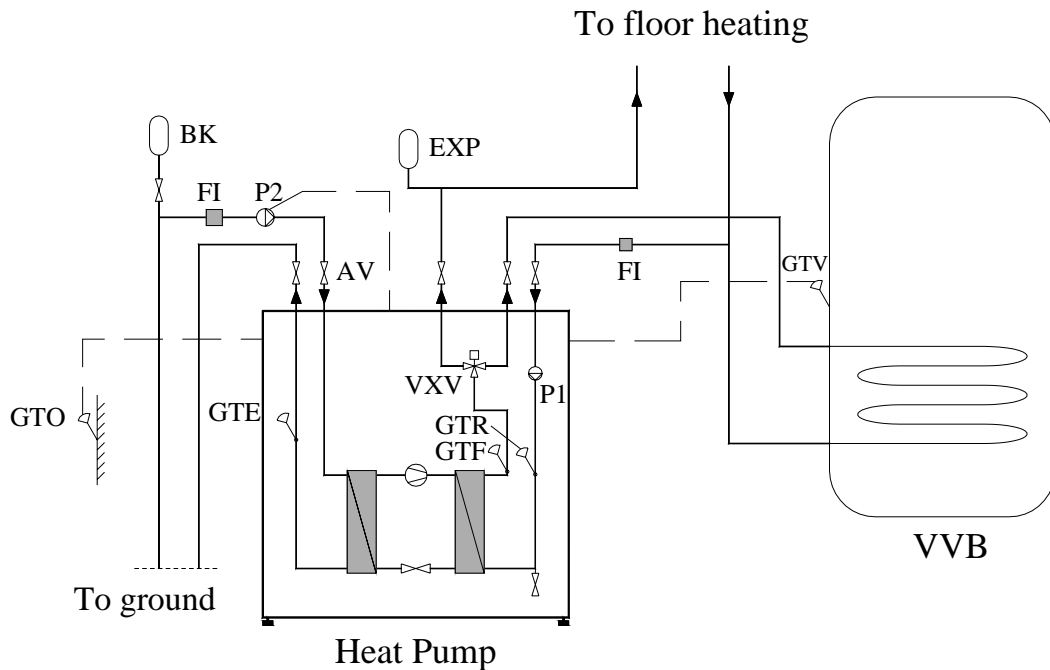

Diagram III

Name	Description	Included?	Name	Description	Included?
P1	Circulation pump	Internal(Optional)	GTR	Return temperature sensor	Internal
P2	Brine pump	External(Optional)	GTF	Flow temperature sensor	Internal
VXV	Change over Valve	Internal(Optional)	GTE	Brine water flow sensor	Internal
VVB	Hot water tank	-	GTV	Hot water sensor	Internal
EXP	Expansion tank	-	GTO	Outdoor temperature sensor	Internal
BK	Brine tank/expansion tank	-			
FI	Filter	-			
AV	Shut-off valve	-			

Principle of operation (Diagram III)

The unit has installed a three way revert valve (VXV). When daily hot water are required, the three way revert valve (VXV) will have the priority to revert to the hot water tank (VVB). After the daily hot water reach its set temperature, the three way revert valve (VXV) return to its normal floor heating circulation.

In order to have daily hot water function, be sure to switch " X2 " on the PC board to " ON " state (refer to the controller part).

The hot water temperature sensor (GTV) is a standard part to be installed into the electric box,

one terminal is connected with the PC board, the other terminal must be connected with the hot water tank. It should be mounted on the place where can accurately induct the hot water temperature.

The outdoor temperature sensor (GTV) is a standard part to be installed into the electric box, one terminal is connected with the PC board, the other terminal must be installed outdoor. It should be mounted on the place where can accurately induct the outdoor temperature and not to be exposed under the rain and snow.

The three way revert valve (VXV) and brine water pump are controlled by the PC board of the unit.

Pipe connections

4、 Free cooling

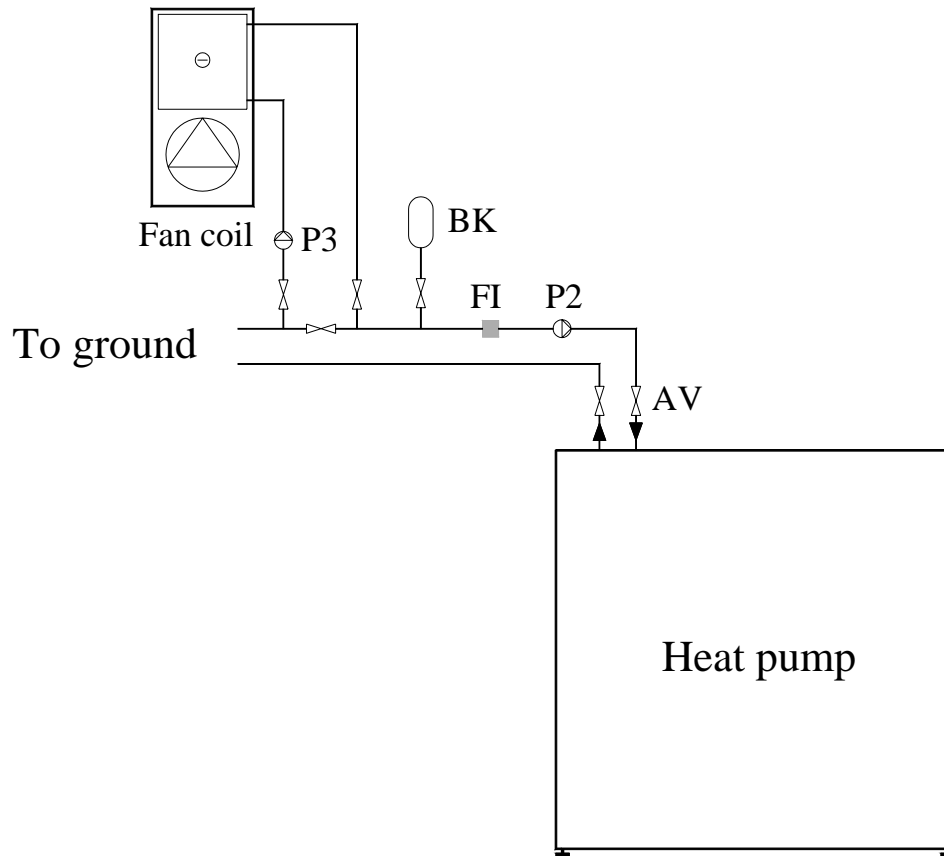

The equipment can be supplemented with a fan coil unit to make the connection of free cooling possible. To avoid condensation, all pipes and other cold surfaces must be isolated with diffusion-proof material. Where the cooling demand is high, fan convectors with drip trays and drain connection are needed. The collector circuit should be fitted with a pressure expansion vessel. If there is a level vessel, this should be replaced.

Pipe connections

5、 Pipe connections

Pipe installation must be carried out in accordance with current norms and directives.

The heat pump has a max return temperature of approximately 50°C and an outgoing max temperature from the heat pump of approximately 60°C.

Since the heat pump is not fitted with shutoff valves(AV), these must be fitted outside of the heat pump to facilitate future service.

NOTE!

The pipe work must be flushed before the heat pump is connected, so that any contaminants do not damage the components parts.

6、 Pipe connections(collector)

When dimensioning the collector, consideration must be given to the geothermal location, type of rock and ground and the degree of coverage provided by the heat pump.

When installing the collector hose ensure it rises constantly towards the heat pump to avoid air pockets. If this is not possible, install high points to vent the air.

All brine pipes in heated rooms must be insulated against condensation. The level vessel(BK) must be installed as the highest point in the collector system and on the incoming pipe before the brine pump. Note that condensation may drip from the level vessel. Position the vessel so that this does not harm other equipment.

As the temperature of the collector system can fall below 0°C it must be protected against freezing down to -15°C. One litre of ready mixed brine per meter of collector hose is used as a guide value when making the volume calculation.

The level vessel must be marked to show the type of antifreeze used.

Shut-off valves should be installed as close to the heat pump as possible. Fit a particle filter to the incoming pipe.

In the case of connection to an open groundwater system, an intermediate frost-protected circuit must be provided, because of the risk of dirt and freezing in the evaporator. This requires an extra exchanger.

7、 Pipe connections(heating medium)

Pipe connections for the heat medium side are made at the top. All required safety devices, shut-off valves(as close to the heat pump as possible), and particle filter are fitted.

You should fit either an overflow valve or remove some of the thermostats when connecting to systems with thermostats on all the radiators.

Electrical connection

The equipment must not be connected without the permission of the electricity supplier and must be connected under the supervision of a qualified electrician.

The equipment must be installed via an isolator switch with a minimum breaking gap of 3 mm. Other electrical equipment, except the outdoor temperature sensor and the current transformer are ready connected at the factory.

Disconnect the heat pump before insulation testing the house wiring.

The heat pump is not reconnectable 1-phase and 3-phase.

When the building is equipped with an earth-fault breaker the heat pump should be equipped with a separate one.

NOTE!

Electrical installation and service must be carried out under the supervision of a qualified electrician. Electrical installation and wiring must be carried out in accordance with the stipulations in force.

1、 Power connection

Before connect the power supply, please confirm the unit adopting power. The units export to Europe market are adopted with 230V/1/50Hz (1 phase) and 400V/3/50Hz (3 phase).

2、 Outside temperature sensor

The outside temperature sensor must be installed in a shaded location on a wall facing north or northwest, where it will not be affected by any morning sun. the sensor is connected to terminals CN5 on the main board.

If the outside temperature sensor cable rubs close to power cabled, screened cable should be used. All conduits should be sealed to avoid condensation in the outdoor temperature sensor capsule.

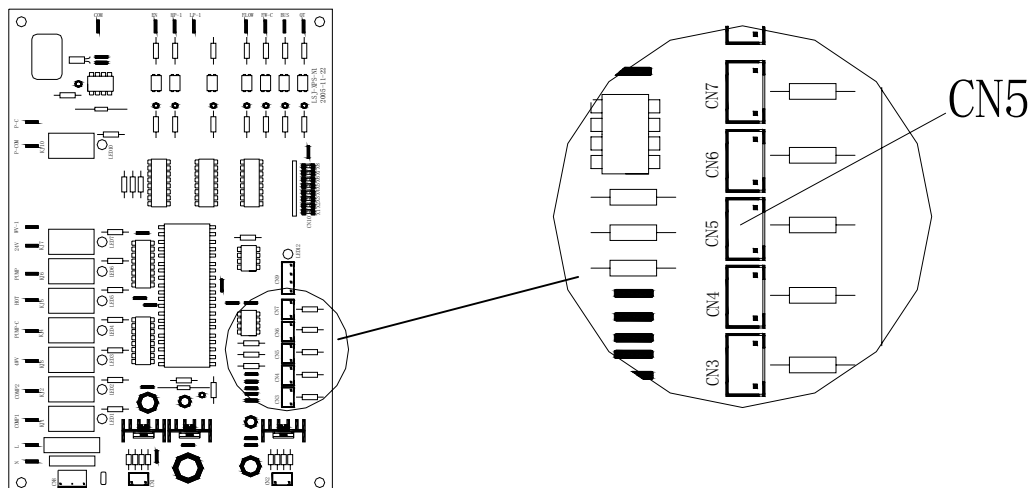

Electrical connection

3、 Temperature sensor for hot water

The supplied sensor is connected using a two-wire cable to terminal positions CN6 on the main board. The sensor is placed in a submerged tube on the accumulator tank.

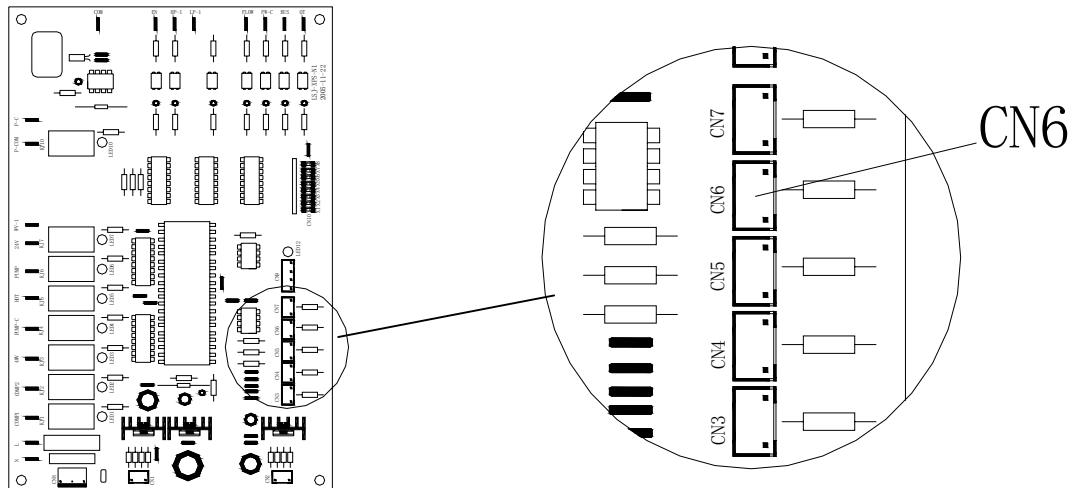

4、 A/C switch

The air conditioner's switch EN must be ON when it is to be started. An external ON/OFF switch could be connected to start or stop the air conditioner part . Also, it can be controlled by connecting the EN port, for detail information, please refer to the unit electric diagram.

5、 Hot water switch

The hot water switch OT must be ON if you want to start the hot water function. An external ON/OFF switch could be connected to start or stop the hot water function. Also it can be controller by connecting the OT port, for detail information, please refer to the unit electric diagram.

6、 Indoor side water flow switch

The water flow switch is to check if the water is flowing or not in the pipe system. If it is ON, the water is flowing and the compressor can be started; otherwise, the compressor is prohibited to start. The connection of the water flow switch, please refer to the unit electric diagram.

7、 Outdoor side water flow switch

The water flow switch is to check if the water is flowing or not in the pipe system. If it is ON, the water is flowing and the compressor can be started; otherwise, the compressor is prohibited to start. The connection of the water flow switch, please refer to the unit electric diagram.

8、 Alarm unit's output

If something gone wrong with the unit, there is alarm signal output. The user could connect a alarm unit (such as indication lighter、 alarm bell etc), the detail information, please refer to the unit electric diagram.

Electrical connection

9、Function selection

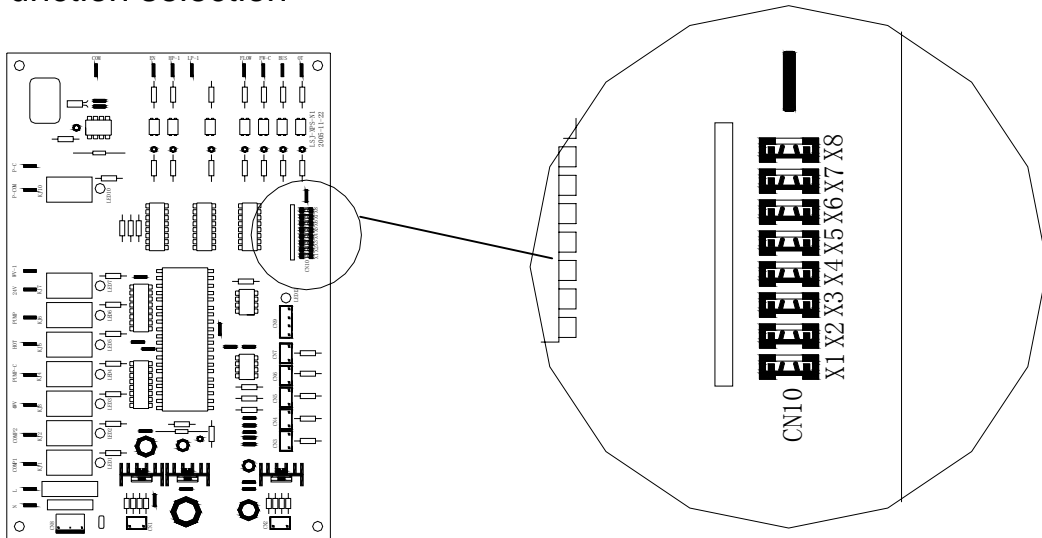

The controller is multi-function which can be realized through the eight jumper or wire (X1,X2,X3,X4,X5,X6,X7,X8) on CN10 of the PC board.

Data	Original set	ON	OFF
System connection X1	ON	Single compressor	Double compressor
Hot water function X2	ON	With hot water	No hot water
Hot water control X3	ON	With hot water temp. sensor	No hot water temp. sensor
Memory for power off X4	ON	Keep the original work state after power turned on again	Turn off when power turned on again
Cooling selection X5	ON	Cooling permitted	Cooling prohibited
Heating selection X6	ON	Heating permitted	Heating prohibited
Self-diagnose X7	OFF	Customer is prohibited to use	
Temp. set method for heating X8	ON	Fix the water return temperature	Change the water return temperature

NOTE!

- Any changes of the setting data must be finished by qualified

engineer.

- X1 will be set by the compressor quantity of the system.
- X2, X3, X4, X8 can be adjusted at the project spot according to the actual situation.
- Please pay attention to any changes for X5 and X6, as your setting may cause the damage of the unit.
- Please do not change the X7 data on the unit.

Control

1、 Controller display (display window)

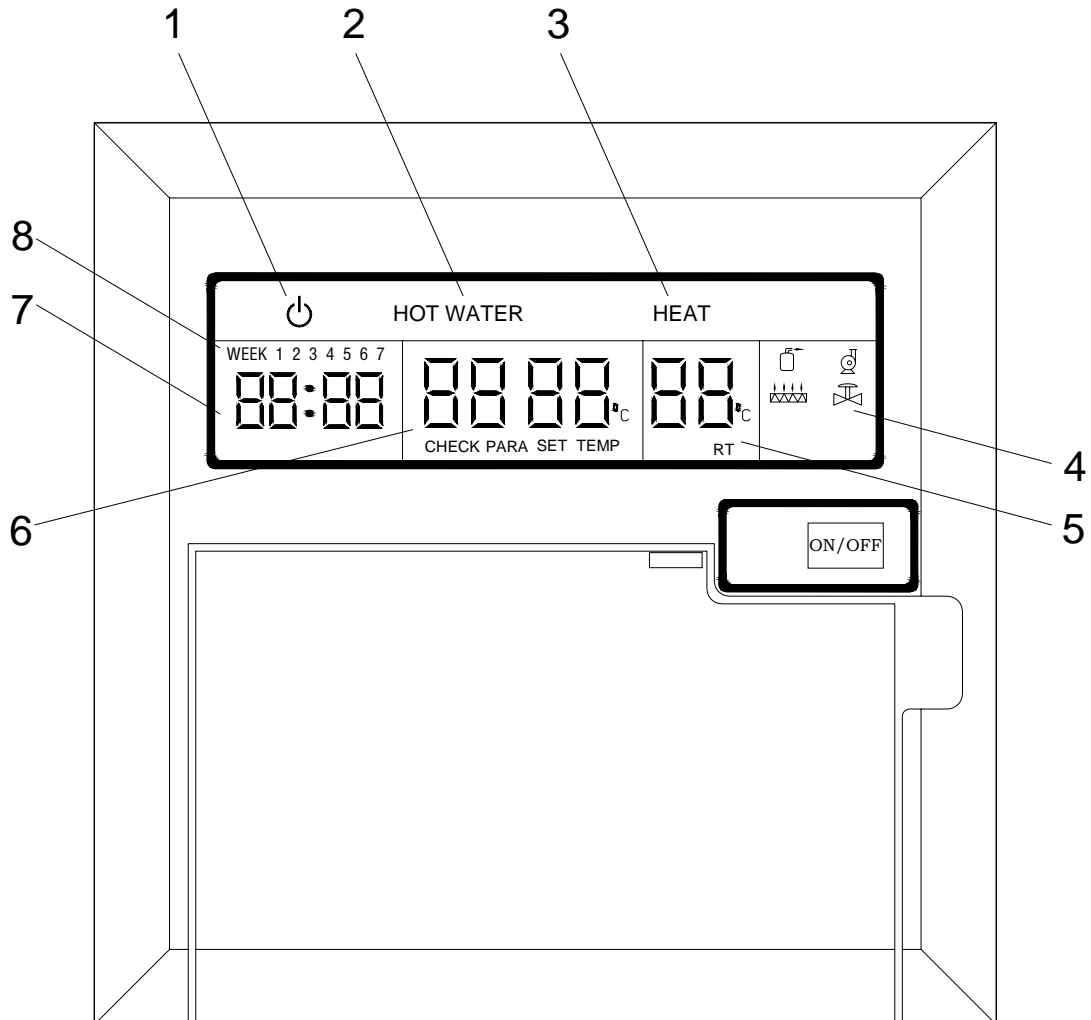

- 1、 The label for turn on the unit. ON will display and OFF will disappear.
- 2、 Hot water mode: will display when it produces hot water.
- 3、 Heat mode: will display when it is heating.
- 4、 Parts running state display
 - the compressor is running; water pump is running;
 - electric heater is working; 4 way valve is working (Cool and heat unit valid);
- 5、 The actual temperature area. It normally shows the actual water return temp. It will display the set data when check or set the data.
- 6、 Set temp. area. It normally shows the water return's set temp. It will show the data code when check or set the data.
- 7、 Clock area. It normally shows the local time. It will show the timed clock.
- 8、 Week area. Show the week day.

Control

2、 Controller display (button area)

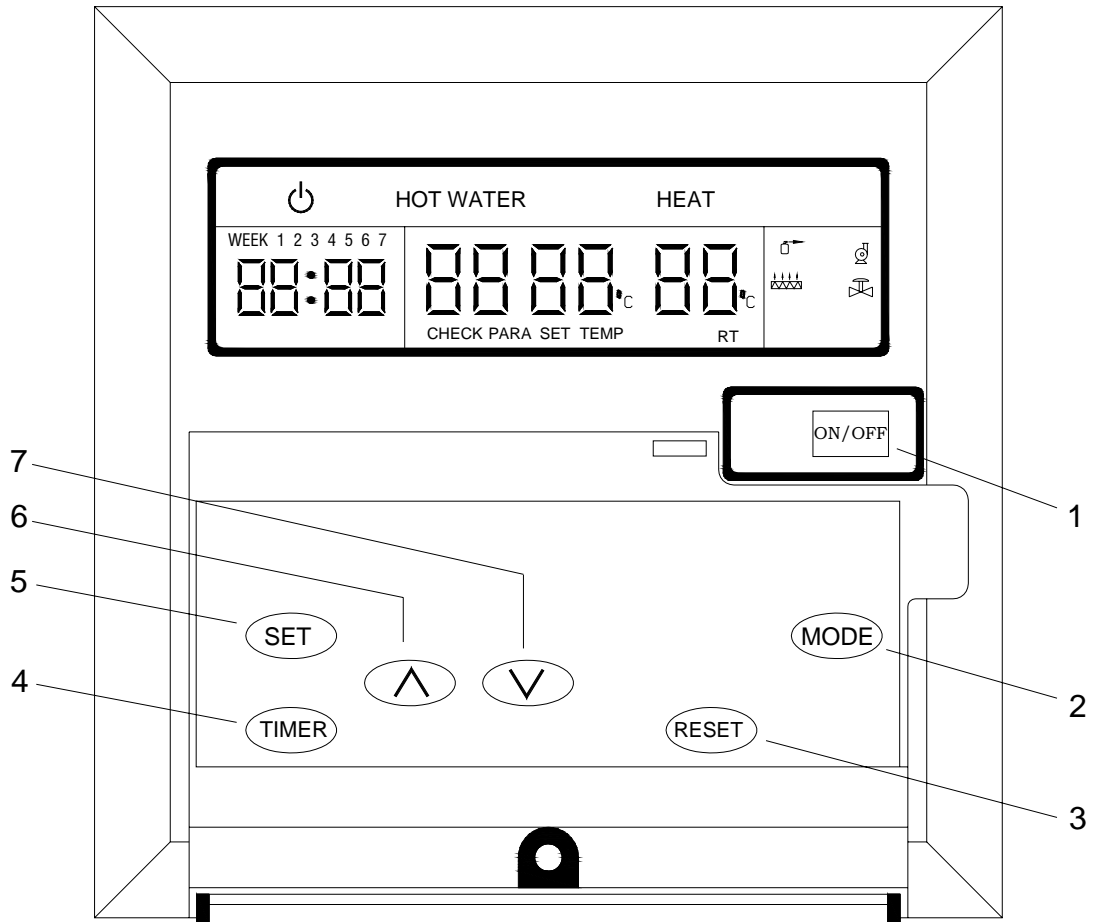

- 1、 ON/OFF button, press one time ON, press again OFF
- 2、 MODE button, select COOL or HEAT mode. For the heat pump unit, there is only heat mode.
- 3、 RESET button, to cancel the trouble code.
- 4、 TIMER button, to set the time.
- 5、 SET button, to check and set the data.
- 6、 Δ button, to increase the data value.
- 7、 ∇ button, to decrease the data value.

Control

3. Change the control temperature.

Press Δ and ∇ to change the temperature data.

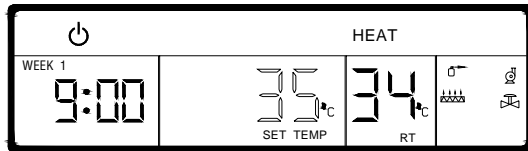

When CN10-X8=ON of the PC board, the control temp. is the indoor side water return temp.

When CN10-X8=OFF of the PC board, the control temp. is the indoor room temp,

4. Change the clock and week

The following step can change the clock and week set data:

① Press TIMER button for 10 seconds to get into CLOCK set

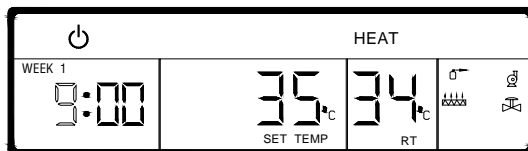

② Press Δ and ∇ to change the hour data.

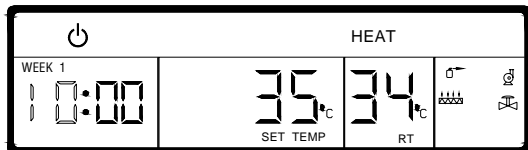

③ Press SET button to show the adjustable minute data.

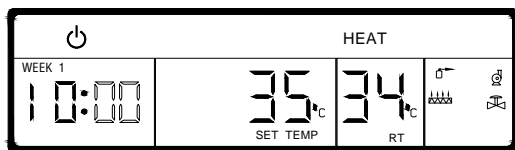

④ Press Δ and ∇ to change the minutes data.

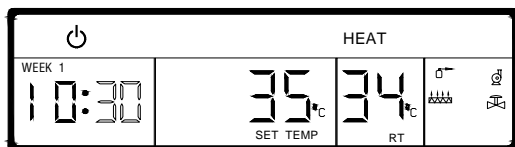

⑤ Press SET again to show the adjustable week data, press Δ and ∇ to change the week data.

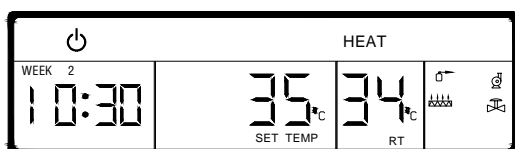

Control

5、 Change the system temperature data

The following steps can change the system temperature data.

① Press SET for 10 seconds to get into the system temperature set program.



② Press Δ and ∇ to change the right data.



③ Press SET button to change the data type.



④ Repeat the above ②③ steps can verify SP01 to SP10 data.

⑤ Stop press any button for 10 seconds, quit the set program.

a .System temperature data parameter

Data description	Data No.	Original set	Max.	Min.	Cancel
A/C return difference temperature.	SP01	1°C	5°C	1°C	
Grade difference temp.	SP02	1°C	5°C	1°C	
Hot water temp.	SP03	50°C	70°C	20°C	
Hot water's Return difference temp.	SP04	5°C	10°C	1°C	
Electric heater start temp.	SP05	30°C	70°C	20°C	
Electric heater's Return difference temp.	SP06	3°C	10°C	1°C	
Indoor side antifreeze when cool	SP07	3°C	8°C	1°C	--
Outdoor side antifreeze when heat	SP08	--	8°C	-10°C	--
Winter antifreeze protection	SP09	3°C	8°C	-2°C	--
Heat curve	SP10	6	20	3	

Control

6、Heat curve (when CN10-X8=OFF)

There are two kinds of set methods to control the heat temperature, fix temp. and changeable temp. Fix temperature means that the return temp. is fixed. This data can be set by the customer directly at the user's area. Changeable temp. is a control temperature (return temp.) determined by both the customer's set room temperature and the outdoor ambient temperature checked by the controller. The function can be selected by setting CN10-X8 of the PC board. If CN10-X8 is ON, it is fix temp, CN10-X8 is OFF, it is changeable temp.

Under changeable temp. mode, the user's set temperature is the room temp. The following is the 20°C room set temperature curve as a example.

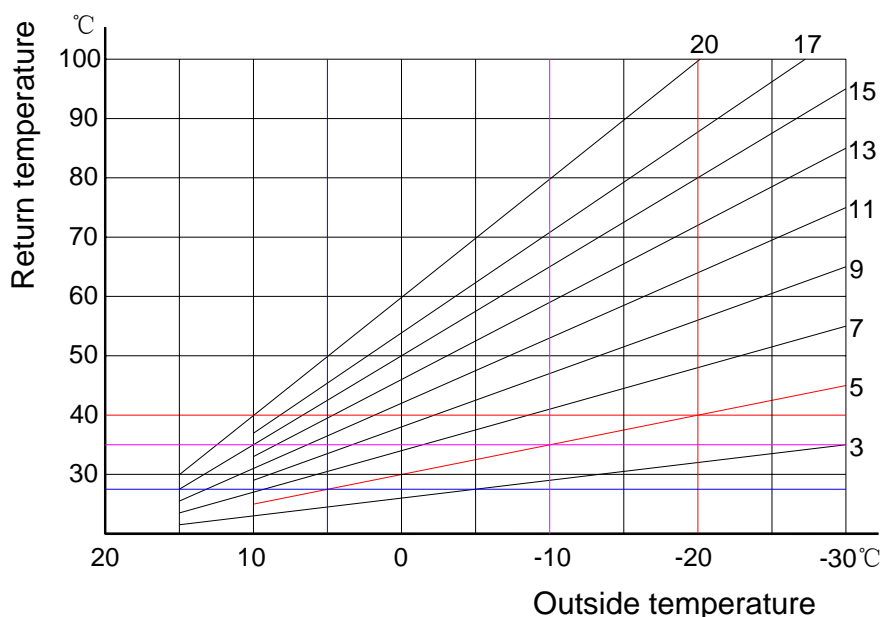

Heat curve SP10 set is 5,

When the outdoor ambient temp. is 5°C, the water return temp. is 28°C;

When the outdoor ambient temp. is -10°C, the water return temp. is 35°C;

When the outdoor ambient temp. is -20°C, the water return temp. is 40°C;

With the lower down of the outdoor ambient temp, higher of the water return temp. will meet the large heating requirement.

With the outdoor ambient temperature increase, the water return temp. will drop down. So the heat pump will work under low pressure to lower down the energy consumption.

7、Temperature check

The following operation can check each temperature sensors data:

① Press SET to get into temperature checking program. The indoor side water return temp. sensor's data will show as follows:

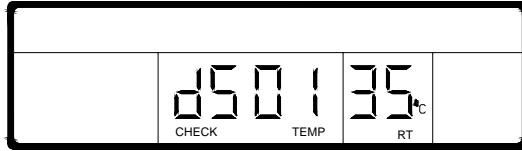

② Press SET again will show the indoor side outlet temp. sensor's data.

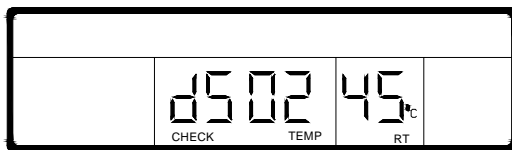

③ Press SET again will show the outside ambient temp. sensor's data

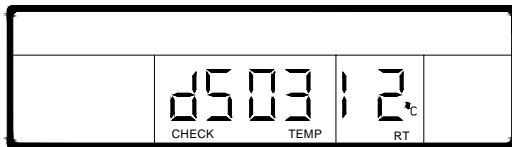

④ Press SET again will show hot water temp. sensor's data as follows.

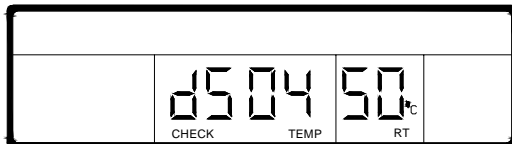

⑤ Press SET again will show the outdoor side outlet temp. sensor's data as follows.

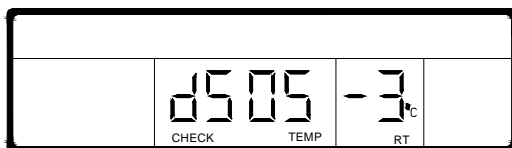

⑥ Stop press any key for 10 seconds will quite from the set program.

Control

8、Timer set

The following operation can set the timer data.

① Press SET for 10 seconds to get into system temperature set program. Press SET until the following appear.



② Press Δ and ∇ to change the hour data.



③ Press SET to show the adjustable minute data.



④ Press Δ and ∇ to change the minute data.



⑤ Press SET again to display the second timer.

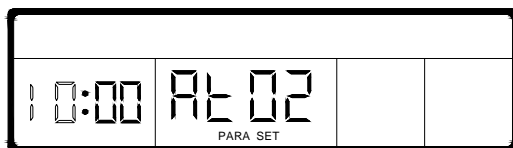

⑥ Repeat the above ②-⑤ steps can set all the timer data.

⑦ Stop press any key for 10 seconds will quite from the set program.

Control

- The timer data

Data	Code No.	Original set data	Explanation
1# A/C timer ON	At01	12: 00	A/C timer ON from Mon. to Fri.
1# A/C timer OFF	At02	12: 00	A/C timer OFF from Mon. to Fri.
2# A/C timer ON	At03	17: 00	A/C timer ON from Mon. to Fri.
2# A/C timer OFF	At04	17: 00	A/C timer OFF from Sat./Sun.
1# Hot water timer ON	Ht01	12: 00	Hot water timer ON from Mon. to Fri.
1# Hot water timer OFF	Ht02	12: 00	Hot water timer OFF from Mon. to Fri.
2# Hot water timer ON	Ht03	17: 00	Hot water timer ON from Mon. to Fri.
2# Hot water timer OFF	Ht04	17: 00	Hot water timer OFF from Mon. to Fri.
3# Hot water timer ON	Ht05	9: 00	Hot water timer ON from Sat./ Sun
3# Hot water timer OFF	Ht06	9:00	Hot water timer OFF from Sat./Sun.
4# Hot water timer ON	Ht07	16:00	Hot water timer ON from Sat./Sun.
4# Hot water timer OFF	Ht08	16:00	Hot water timer OFF from Sat./Sun.

NOTE!

If the timer ON and OFF is set at the same time for the same group, then the group timer will be invalid.

Trouble alarm

Trouble Code	Trouble description	Trouble reason	Protection	Revert condition
E-00	Communication problem	Unusual communication	Cable controller will alarm	Normal electric communication
E-01	Indoor side water flow switch turn off	Indoor side water flow switch turn off for 5 seconds	System will be turned off	Press RESET to revert
E-02	Outdoor side water flow switch turn off	Outdoor side water flow switch turn off for 5 seconds.	System will be turned off	Press RESET to revert
E-03	Phase/lack of phase	Phase/lack of phase checking board switch turn off	System will be turned off	Press RESET after the protection switch revert its normal condition
E-04	Set troubles	Prohibit cool and heat at the same time	The system can not be turned on	Power OFF and reset again
E-05	System pressure too high	The system HP switch turn off for 5 seconds.	Compressor stop at once	Press RESET after the HP switch revert
E-06	System pressure too low	System LP switch turn off for 5 seconds after the compressor runs for 5 minutes	Compressor stop at once	Press RESET after the LP switch revert
E-07	The outdoor side temp. sensor broken	The temp. sensor short-circuit or turn off	Cool permit, heat/hot water prohibit (if SP08 valid)	Press RESET after repair or change the temp. sensor
E-08	Hot water temp. sensor broken.	The temp. sensor short-circuit or turn off	Cancel hot water function	Press RESET after repair or change the temp. sensor

E-09	$T_{\text{ambient temp.}}$ sensor broken	The temp. sensor short-circuit or turn off	Cancel relative function	Press RESET after repair or change the temp. sensor
E-10	The indoor side outlet temp. sensor broken	The temp. sensor short-circuit or turn off	Permit heat/hot water, prohibit cool	Press RESET after repair or change the temp. sensor
E-11	The indoor side water return temp. sensor broken	The temp. sensor short-circuit or turn off	System turn off	Press RESET after repair or change the temp. sensor
E-12	Indoor side water flow switch winter antifreeze protection	OFF state $T_{\text{indoor water return}} \leq \mathbf{【SP09】}$	The unit heat working	Turn on the unit or $T_{\text{indoor water return}} \geq \mathbf{【SP09】} + 6^{\circ}\text{C}$
E-13	Outdoor side antifreeze of heat mode	Outdoor side outlet temp. $\leq \mathbf{【SP08】}$	Stop compressor, outdoor as well as indoor side water pump go on working	Outlet water temp. $> \mathbf{【SP08】} + 10^{\circ}\text{C}$ and press RESET
E-14	Indoor side antifreeze of cool mode	When cool mode, Outlet temp. $\leq \mathbf{【SP07】}$	Stop compressor and outdoor side water pump	Outlet water temp. $> \mathbf{【SP07】} + 10^{\circ}\text{C}$ and press RESET

Dimensions

1、GSWW8/10/13/15 unit:mm

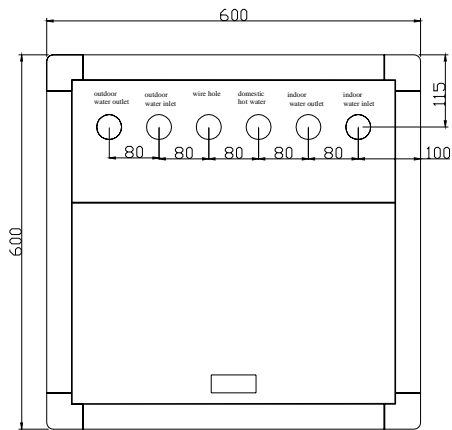
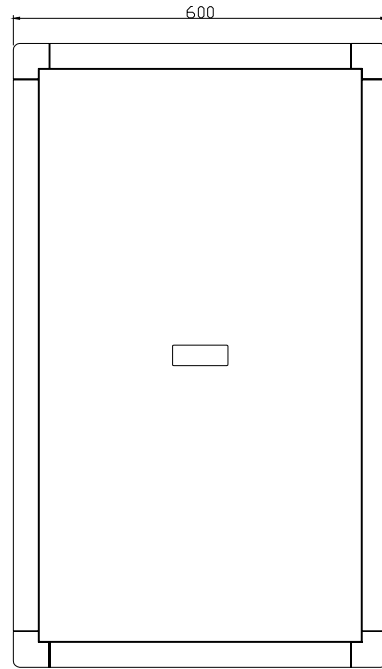
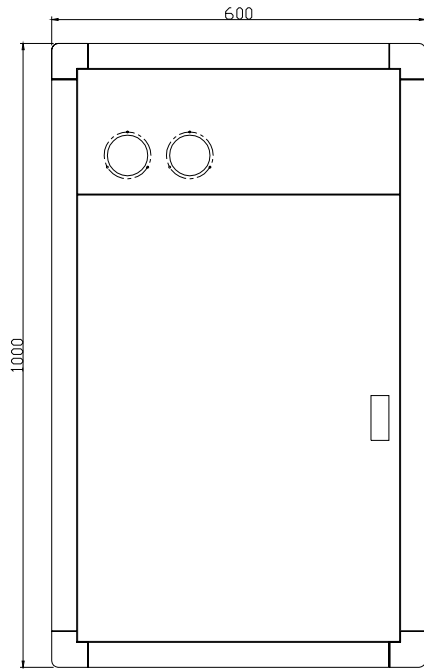

Dimensions

2、GSWW20/26/30 unit:mm

